

ID	Description	Date	By	Appr.
A	New	04.12.2018	ATo	

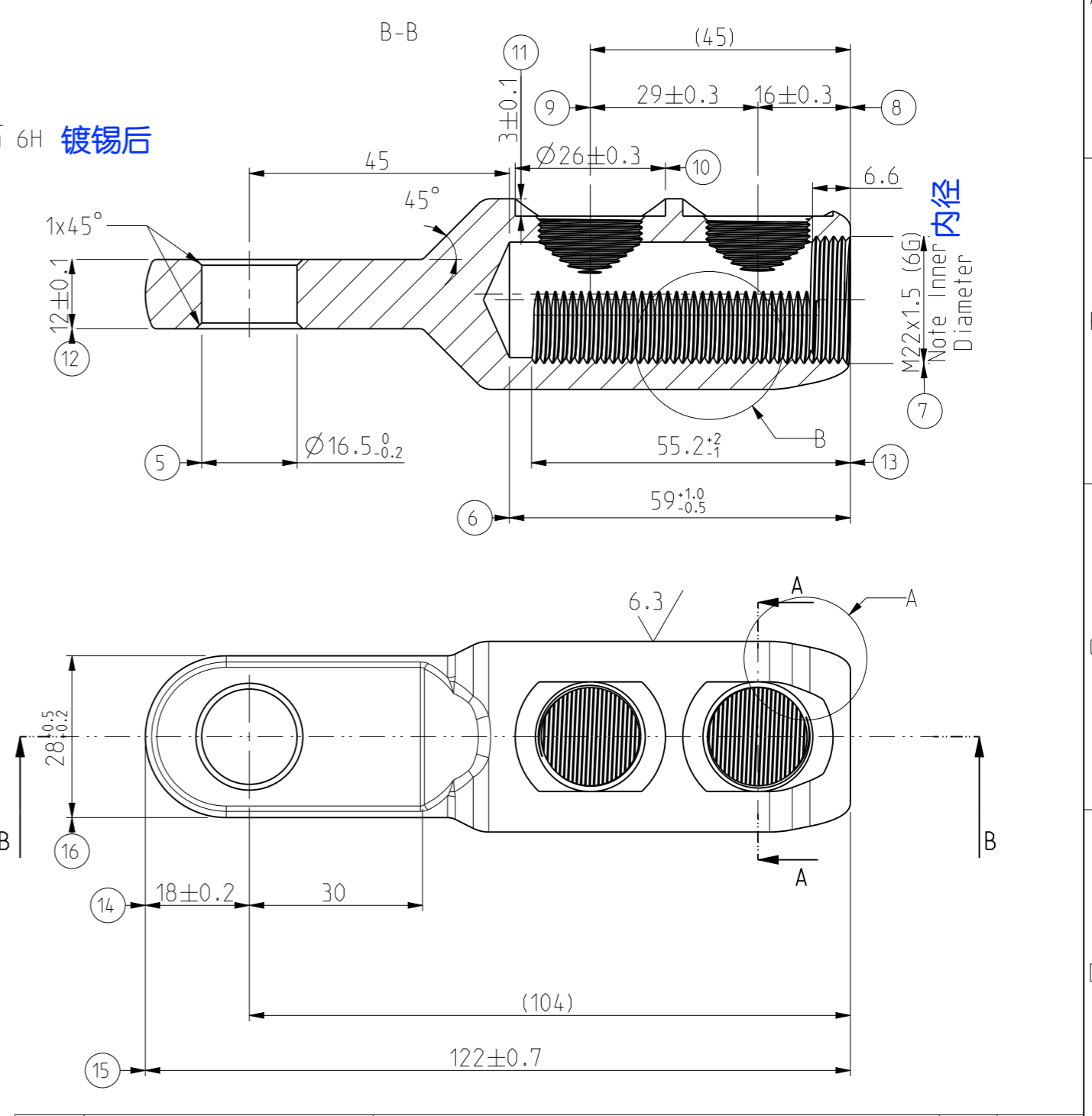

Part	Code	Description	Pcs	Weight (g)/pcs
Supplier: -		Tool No: -	Volume: -	Weight (g) 125
Material: AA6082 T6 材料				
Scale: 1:1		Date: 02.10.18	Replaces:	
A3		By: ATo	Replaced:	
Sheet No: 1 (1)		Checked:	Drw No: 000441336 A	
		Ctrl:	Ref: PDA240.630A	
			Code: PDA240.630A-B	

Model: PDA240-630A-B part [A]
Drawing: PDA240-630A-B.dwg

Tolerance: ISO 2768-m

>0.5 =3 ±0.1

>6 =30 ±0.1

>6 =30 ±0.2

>30 =120 ±0.3

>120 =400 ±0.5

>400 =1000 ±0.8