

此处测量锡的厚度
Measure tin thickness here

平滑锻造毛刺
Smoothen forging burrs
all around the part.
Sharp edges are not allowed
无飞边

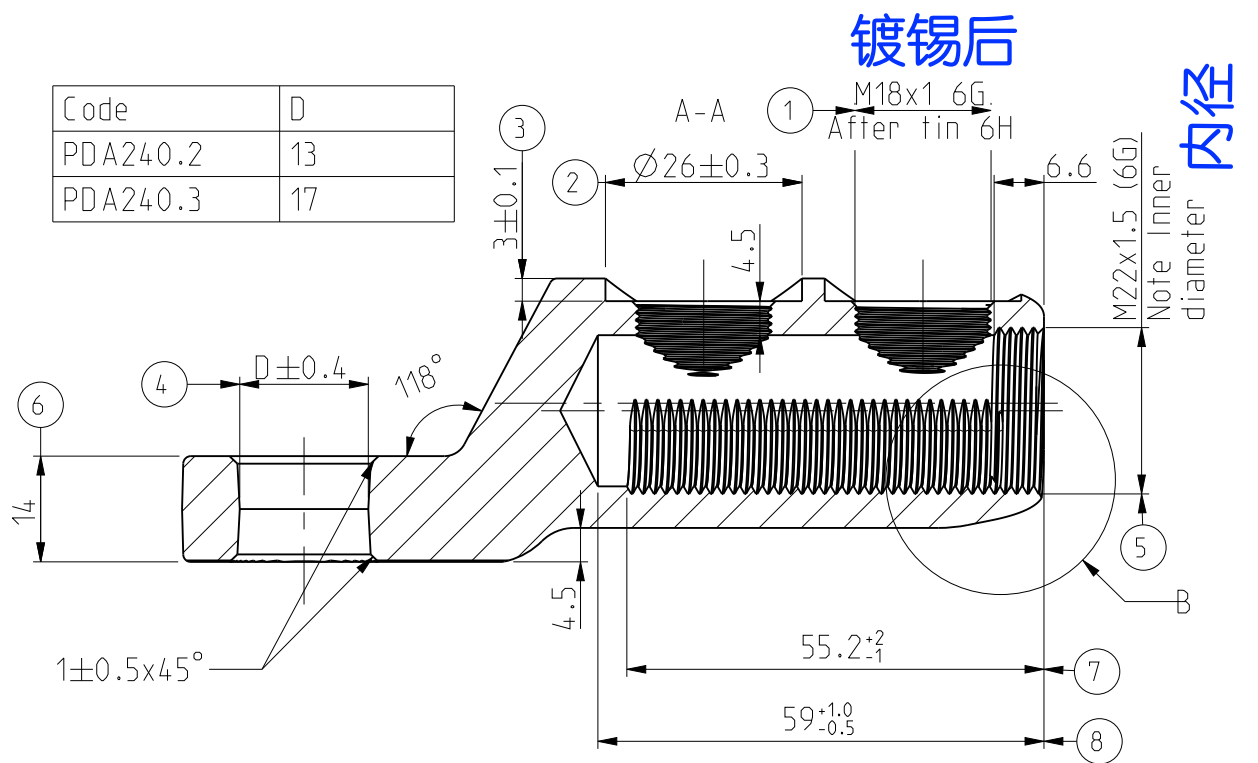

Code	D
PDA240.2	13
PDA240.3	17

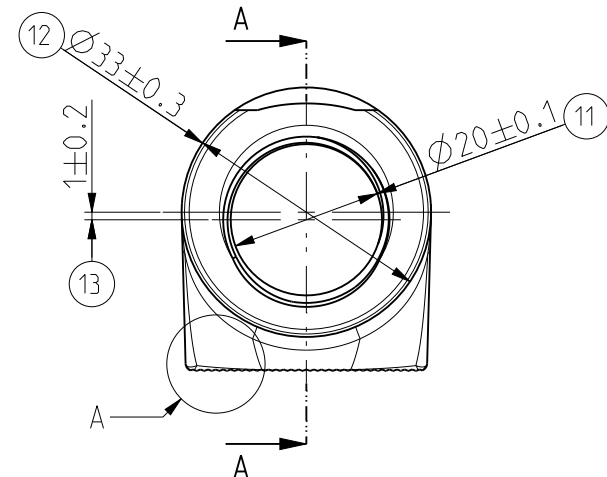
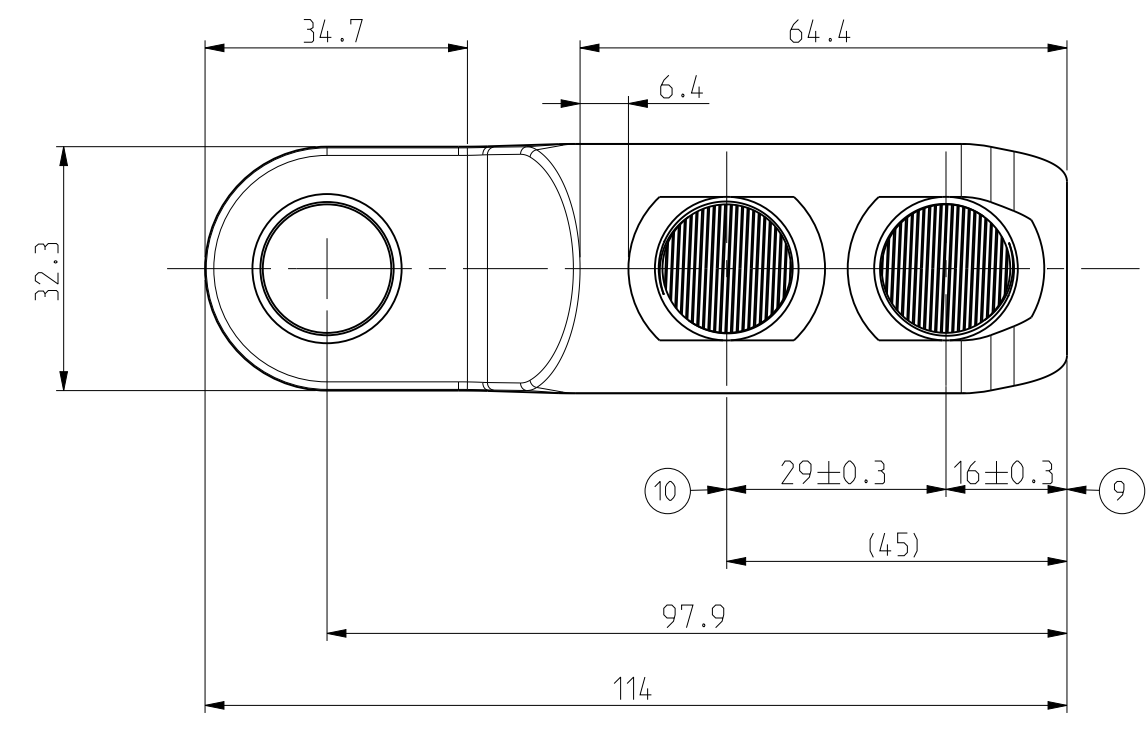

镀锡

Surface Treatment: Tin plating 12±2 µm

Symbol	Instruction of the Symbol	No. of Dim
⊕	Basic Dimension. To be measured in full measurement of part	12
⊖	Cpk dimension. To be measured in process capability study	-
⊙	SPC dimension. To be measured during production	-

Note: All numbered dimensions are to be measured in full measurement

Part	Code	Description	Pcs	Weight (g)
Supplier: -	Tool No: -	Volume: -	Weight (g): 135	
Material: AA6082 T6 材料				
Scale: 1:1		Date: 18.09.18	Replaces:	
A2		By: ATo	Replaced:	
Checked:			Draw No: 000427751 A	
Ctrl:			Ref: PDA240.13, PDA240.17	
Sheet No: 1 (1)			Code: PDA240.X	