

ID	Description	Date	By	Appr.
A	New	04.12.2018	ATo	

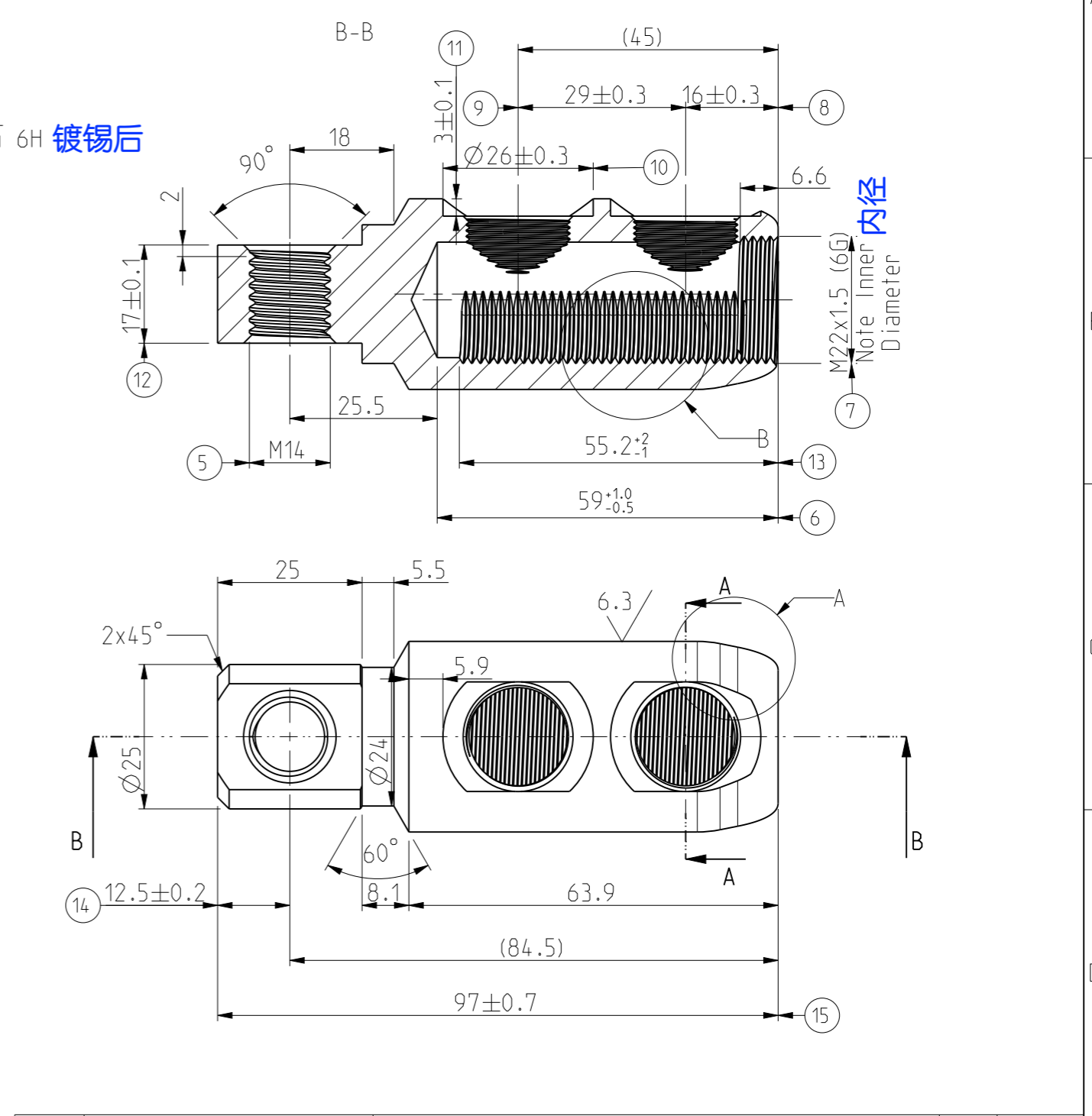

Part	Code	Description	Pcs	Weight (g)/pcs
Supplier: -	Tool No: -	Volume: -	Weight (g)	108
Material: AA6082 T6 材料				
Scale: 1:1		Date: 02.10.18	Replaces:	
A3		By: ATo	Replaced:	
Sheet No: 1 (1)		Checked:	Drw No: 000444528 A	
Ctrl:		Ref: PDA240.400A		
		Code: PDA240.400A-B		

Surface Treatment:	Tin plating 12um (+2/-2) 镀锡
Heat Treatment:	T6
Inspection Instruction:	Inspection dimensions marked with numbers