

CONFIG	L
A	0.55
B	0.45

REVISIONS				
ZONE	REV.	DESCRIPTION	DATE	APPROVED
	B	Back side bend to improve overmolding process	12/12/2018	
	C	Forward tip size reduce Back tip material remove instead of bending	16/12/2018	

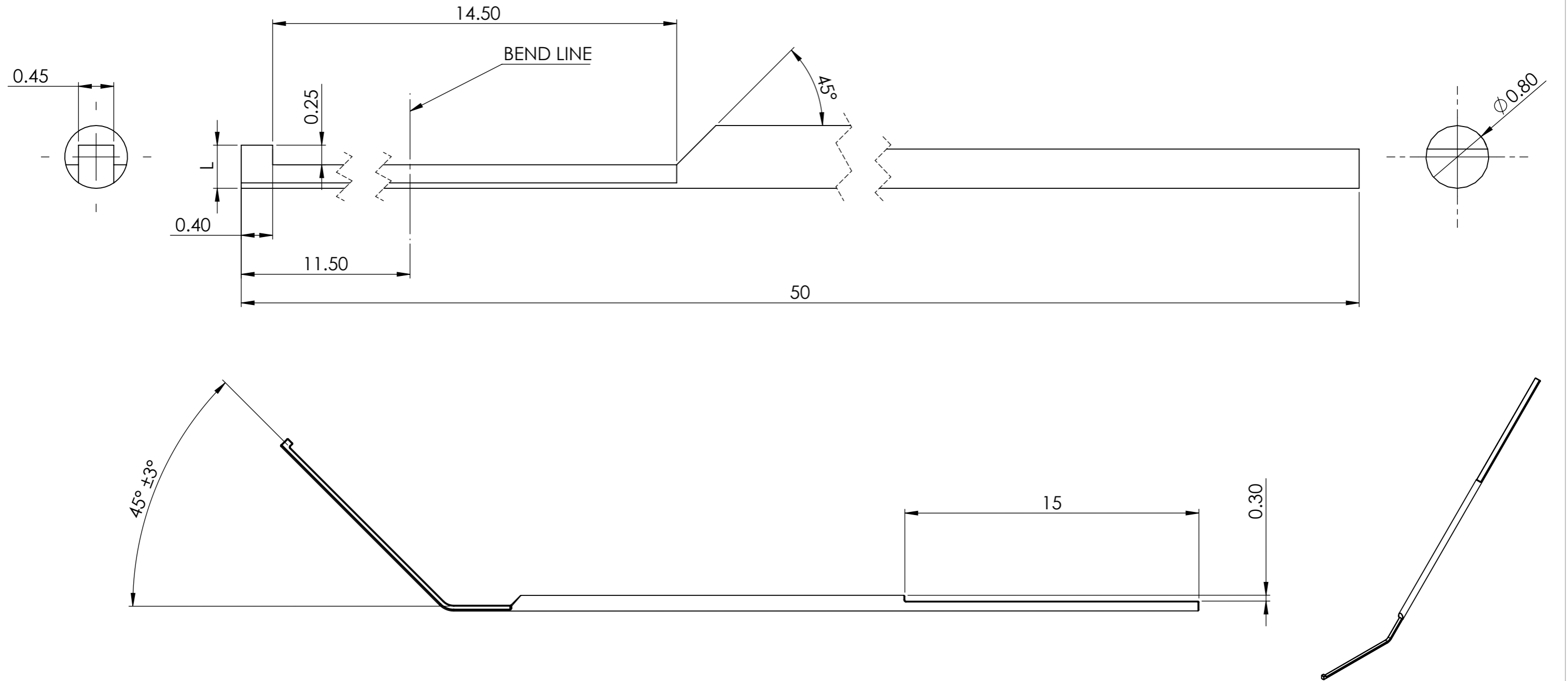

NOTES:
 1. Do not scale drawing.
 2. Missing dimensions according to model.
 3. DEBUR AND BREAK SHARP EDGES

General Surface Finish:
Electropolish

UNLESS OTHERWISE SPECIFIED:
 DIMENSIONS ARE IN MILLIMETERS
 LINEAR: ±0.05
 ANGULAR: ±1°
 Concentricity: ±0.05
 General Tolerances: ISO-2768 (f)

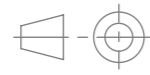

COMPANY	NAME	SIGNATURE	DATE
SINAI MEDICAL	DESIGNED Boris		
SINAI MEDICAL	CHK'D Doron		
CORNEAT VISION	CHK'D Patricia A.		
CORNEAT VISION	Q.A. Gerry T.		
CORNEAT VISION	APPV'D Almog A.R.		

Material: **SS316** Quantity: **XX**

Company: **CorNeat Vision**

Part Name: **Snapper tip**

Drw.No: **DRW-20001** Rev: **C**

